

ELECTROMAGNETICAL ENVIRONMENT AND SAFETY FOR LARGE SENSITIVE SYSTEMS

A NEW APPROACH AND FIRST SOLUTIONS

¹Daniel Soleil, ²Alain Alcaras [26-29 Juin 2007 in St Petersburg - Russia]

¹Bureau d'Etudes CEMS, 801 Route d'Eyguieres, 13560 Senas (F). Tél : (+33) (0)4 90 57 28 14
Fax : (+33) (0)4 90 57 25 12 – e-mail : daniel.soleil@wanadoo.fr - <http://pro.wanadoo.fr/geniecem>

²Thales Communications, 92-Colombes,
Tél : (+33) (0)1 41 30 30 71- Fax : (+33) (0)1 41 30 24 30, e-mail : alain.alcaras@fr.thalesgroup.com

1- Abstract: This paper presents the main considerations about the application of a new EMC concept on the electromagnetic compatibility studies and protections. This concept specifically adapted for large and complex systems called the “zero method”. This method allows hospitals, computers, power, gas and petroleum plants etc ...to find quickly economic and technical good solutions against electromagnetic interferences made by lightning effects and industrial disturbances effects. The efficiency of these solutions is confirmed along ten years of operation.

2. Electromagnetic Compatibility « system »

Current problems and international tendencies. The EMC domain is a field characterized primarily by phenomena of interaction [1]. Any usual approach which consists in trying to separate the problems in order to treat them most effectively possible [2], encounters all the more important difficulties as the systems are more complex.

State of the art on EMC system. The field of the Electromagnetic Compatibility of systems is still at the stage of the studies and the project standards, even at the international level. This research is based on tests, metrology and complex coupling calculations. Among the studied systems, aeronautics, nuclear power and weapon systems are the first supports, in particular concerning the lightning protection.

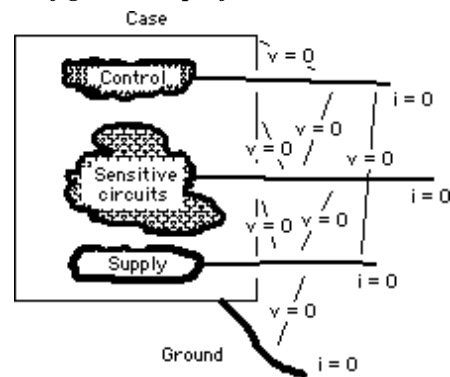
Zero Method – A tool for EMC System studies. The Zero Method is a research orientation connected to the other common research, supported by a specific metrology on the field [3] and a simpler access, reserved to the industrial facilities, practical and economic, matched to non-specialists on theoretical electromagnetism who use sometimes heavy means of measurement and calculations. The Zero Method does not need stimulation of circuits; it uses the existing electromagnetic environment.

Zero Method: Only 2 criterions. This new concept is based on an obvious fact that a reference potential remains a reference only if no HF current (usually from 10 kHz to 10 MHz) circulates in its conductors, and that there are no HF voltage between different reference potentials (fig.1.), whatever it occurs.

What are the reference potentials? In the current installations, one can count with more the six potentials “of reference”:

- Mass,
- Earth
- “Zero” associated electronic sensitive system
- DC Energy
- AC Energy
- “Zero” associated Communications system

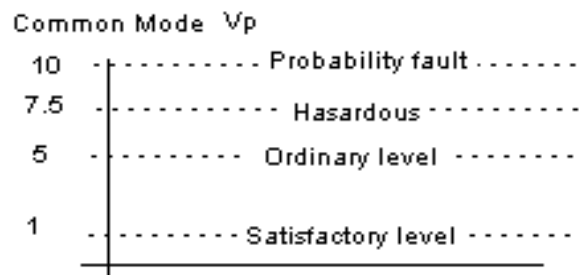
fig. 1. Concept of the Zero Method



Feedback experience on the significant sites. In practice, it is recognized that the “Zero” are ideal and non-essential in the sensitive installations for former technologies concerning informatics and communication (tolerance to the signal-to-noise ratio). For example, the safety begins (fig.2.) to be reached 1 Vc is measured between references,

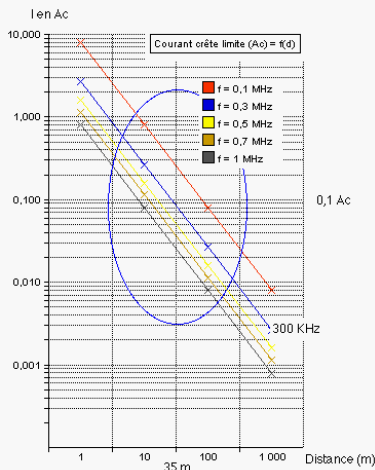
Note. Let us recall that on the very low levels (towards 0); there is no more to worry neither about the frequencies nor of the forms about waves, whereas on the higher levels, these factors become fundamental.

fig 2. Statistic disturbing voltages



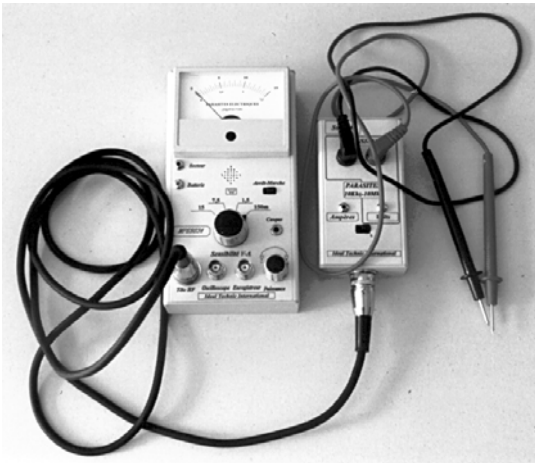
The current limit is calculated easily considering approximately an inductance 1 μH per meter of reference conductors. It results a few hundreds of mA peak for a few tens of meters length of conductor, concerning the frequencies usually concerned.

Fig.3. Statistic disturbing currents



The Perturbometer®. To apply the zero method, a specific equipment (fig.4.) has been designed called the Perturbometer®. It supersedes both the use of an oscilloscope and HF peak voltmeter assembly and demodulation functions to ear the troubles. It provides record and equivalent signal outputs. Its measurement scales are mA to 10 A peak, μ V to 10 V peak and a spectrum from some KHz to several 10 MHz. Other scales and designs are studied.

Fig.4 Perturbometer®



3. Practical analysis inside of a sensitive site

As regards hardening EMC, measurements corrective are to reduce the amplitude of the disturbances while making tend towards the “zero” voltages and currents associated with these potentials. The methodology based on the “Zero Method” was already used with profit for hardening EMC of various sensitive installations subjected to external and internal disturbances.

Scope of Work on the field. The Zero Method needs:

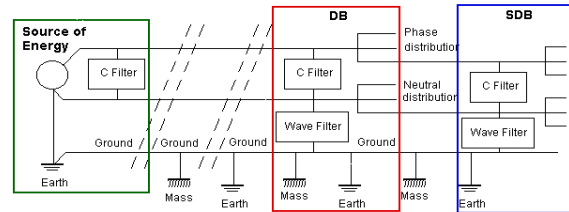
- General report on the observed EMC problems
- Analysis of the schedule of conditions about EMC domain requests
- Short explanations about Zero Method

- Examination of available electrical plans, and constitution of some functional diagram about power supply and sensitive signals for all specialties.
- Gaining a thorough understanding of the electrical circuits.
- Measurements into disturber systems and sensitive systems
- Development of a compatible correction strategy with different parameters such as feasibility, costs, appropriateness etc.
- Possible installation of light corrections to validate some hypothesis.
- Calculations of filters and foreseeable attenuations, strategic choices.
- Succinct conclusions writing on the spot destined to satisfy the requirements of the technical staff in charge of the works.

Target of the Zero Method. The energy is among the first actor which will be worked into a large site. Other actors are also in place (static discharges, lightning ...) and it is possible to explain their effects by similar considerations. This purpose is limited about energy with Neutral earted mode.

Sources of energy and their distributions. The sheme above (fig.5) shows the classical distribution of an earthed Neutral source, triphase for example.

Fig.5. Mains supply for example



A transformer HV/LV feeds energy through several meters length of wires into a Distribution Board (DB), and this DB feeds energy for several Sub Distribution Boards (SDB).

Frequent measurements

- Input disturbances are a lot of HF voltage spectrum whose result can give about 10 V peak for example. The classical industrial spectrum is contain from some KHz to 1 Mhz.
- Finally with experience, it is relatively easy to built efficient filters (C Filter and Wave Filter) to obtain a satisfactory attenuation of the disturbances to reach 1 peak Volt everywhere.
- By experience, the most values of parameters are directly proportional with power, consequently, C filter is proportional with power, and the Wave Filter may be the same for large configurations associated with C Filter.

Two classical configurations. It appears 3 major configurations :

- The attenuation for energy sources (differential mode) => need C Filter
- No common disturbances with earthing arrangement when Neutral is directly connected to the ground.

- The same observation for distributions because length of cables and coupling with the environment which need again the attenuation in differential mode => need C Filter and in common mode => need Wave Filter.
- Each configuration uses different parameters.

4. Theoretical items and example about Zero Method At the source of energy of the LV mains

Differential filter

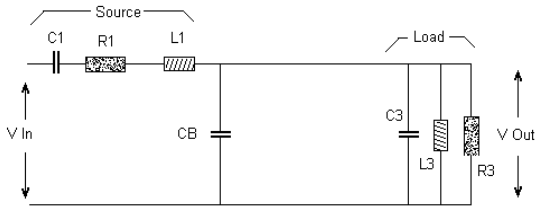
This simplified scheme is fig.7.

- C1 the capacitor between Primary and Secondary of a High or Low voltage transformer as an example
- L1 its leakage inductor of the transformer
- R1 its active losses
- CB the capacitor Block (here is photography of a 3 x 100 µF as an example fig.6.)
- C3, L3, R3 the components of the useful load

fig.6. Capacitors Star Filter Bloc

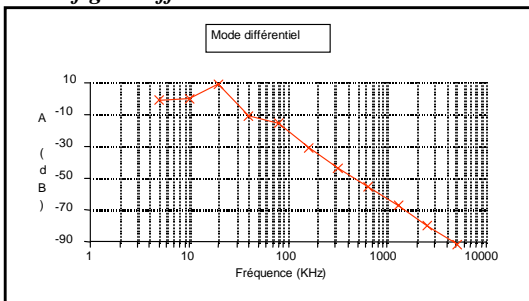


fig.7. Mains supply differential mode filter



With the classical values of the parameters, this diagram (fig.8.) shows more 10 dB attenuation since 40 KHz, when the major HF disturbing effects begin up 100 KHz.

fig.8. Differential attenuation at source



Distribution mains at DB and SDB

Recall there is no common source with Neutral direct earthing (Short-circuit)

For isolated or impedant neutral/earthing, other parameters are needed.

Differential mode attenuation

- In this case, the equivalent capacitor C1 is ∞
- L1 its leakage inductor with the length of cables
- R1 its active losses by the cables
- CB the internal capacity of the filter and eventually

the additive capacitor Block (see upper)

- C3, L3, R3 the components of the useful load

With the classical values of the parameters, the attenuation diagram is similar the precedent one about the source.

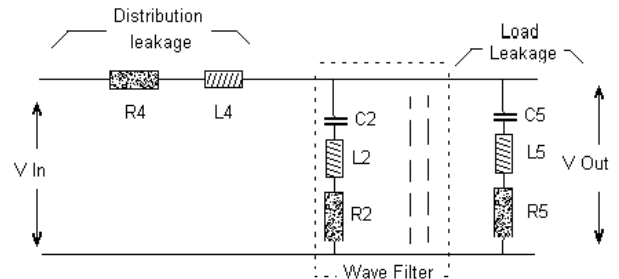
Common mode attenuation.

- In this case, the equivalent capacitor C1 is ∞
- L4 its leakage inductor with the distance
- R4 its active losses by the cables
- C2, L2, R2 etc. confidentially value for Wave Filter (HF Broad band short-circuit). Here is a photography fig.9. of the triphase model – 120 x 120 x 110 mm – 0,8 Kg [4].
- R5, L5, C5 the distributed leakage components of the load

Fig.9. Wave Filter for common mode protection

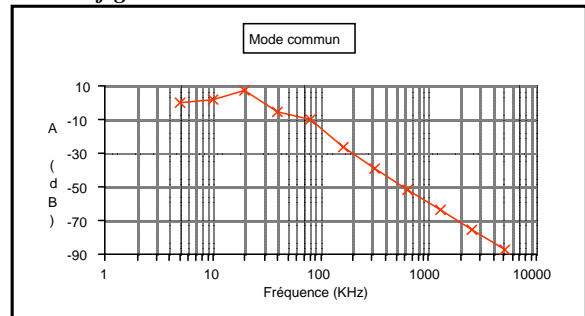


Fig.10. Common mode attenuation at DB or SDB



With the classical values (fig.10.) of the parameters, this diagram (fig.11.) shows more 10 dB attenuation since 80 KHz, when the major HF disturbing effects begin up 100 KHz.

fig.11. Common mode attenuation

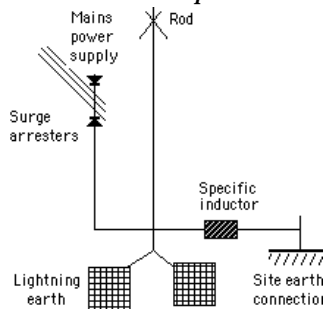


5. Lightning protection

The functioning of the lightning surge arresters 20 KV (for example) and/or the flow of the lightning flash through a rod is going to create violent transitory currents in the ground. Experience shows that it is not conceivable to protect efficiently the sensitive circuits because the complexity [5]. It is better for sensitive

circuits that have to ignore the presence of these high HF currents (only zero method).

Fig.12. Derivated atmospheric discharges

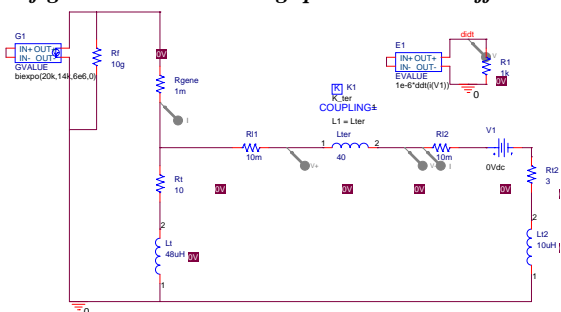


In this way (fig.12.) a pair of redundant metallic plates (each are about 1, 5 m2) transfer correctly the atmospheric charges in the soil by using the surface and the capacitor effects. Stakes can't offer the same HF performances.

A specialized inductor inserted between the interconnection of the lightning earth and the meshed system will separate fictitiously the Low-frequency spectrum which will flow to the earth system. This inductor behaves as an earth cable of classical size, whose loops would be rolled around a specialized magnetic nucleus.

An approach of modelling. The insertion of a component TER (prototype) in a connection between the lightning down conductor and the ground network was modelled (fig.13.) with PSPICE software.

fig.13. SPICE Modelling special inductor effect



This approximate modelling makes it possible to evaluate in a qualitative way the performances of TER with respect to the constraints indicated above.

These performances are synthesized in the following table fig.14.

fig.14. TER Inductor effects

Electric safety	At 50 Hz frequency, calculation shows an impedance of 50 mΩ for a rated current of 50 A , which is coherent with measurements and in conformity with the safety requirements by developing only 2,5 V eff.
Direct Lightning Protection	<ul style="list-style-type: none"> In low frequency, calculations show that the impedance does not exceed 1 Ω. Considering a lightning impulse on the lightning down conductor, the penetrating current in the ground network reach a light attenuation from approximately 15% in peak amplitude, compared with the current du to the short-circuit connection. The most significant effect is the reduction

	in the speed of the current. For the first derivative di/dt , one has a reduction of approximately 20% and for the second derivative di^2/dt^2 (sources of high frequencies) one has a reduction of approximately 30 dB . <ul style="list-style-type: none"> Compared with a traditional coil linear having the same performances in EMC (coil of some mH), TER develops a voltage approximately 6 times less important (considering a 20kA lightning current), which makes it possible to be supported.
EMC Protection	For the high frequencies ($F > 10$ kHz) TER bring an attenuation from approximately 20 dB .

6. Conclusions

Quasi-perfect equipotentiality. Measured in Volts peak, it implies the absence of current in a conductor, the impedance do not need to be reduce while it's in accordance to standard indications.

Experimental regulation of electromagnetic disturbances. The regulation of the conducted disturbances is ensure by the quality of the power sources which receive $\cos \phi$ correction capacitor not in triangle but in star configuration, and whose required function is not any more the rectification of the $\cos \phi$, but a quasi-null HF impedance. In addition, the distributions of these sources « are hardened » in the electromagnetic way, conferring a quasi-insensitivity to them to collect the electromagnetic waves and to drive the voltagess and currents which they drive in a traditional way. Finally, if it's possible, it is imperative to send the lightning current impulses out of the sensitive ground networks which must hold good references, whatever it occurs.

Responsibilities. The theoretical and practical aspects of the concept «Zero Method » shock in the practices, they do not need standardization because they are physically obvious. It is possible that in the future this concept becomes a tool of legal assistance making it possible to better define responsibilities which can be opposed sometimes.

References

1. Maîtrise de la CEM – Technologie, Réglementation, Normes – Les Référentiels Dunod 12-1998
2. NFC 13-100 - NFC 15-10 - NFC 17-100 - NFC 17-102
3. 1995 - SEE - Dauphinée-Savoie - Grenoble (F) (Co-auteurs : Daniel Soleil - Jacques Heim - SPSE): *Maîtrise expérimentale des perturbations radioélectriques et des effets de la foudre.*
4. Ets SARE – Immeuble Hercule, Rue de l'Industrie – 98 000 Monaco “Transformateurs et composants CEM Systèmes » Tél : 00 377 92 05 92 45.
5. International Conference on Lightning and Static Electricity (ICOLSE) held at the Aerospace Congress and Exhibition (ACE) in Seattle, Washington, USA on 11-13 September, 2001 Co-authors : Daniel Soleil - Alain Alcaras – Thales Communications – Colombes : *Lightning protection : Experimental approach for large sensitive systems – example of a nuclear power plant.*